

AQUA DATA

RC2dl V1.2

Operating Manual



Introduction

The Sensa RC2dl unit is intended for use with wading rod and similar type of applications, in both clear and dirty waters. The minimum configuration comprises a surface display and control unit with a velocity probe, supplied in an aluminium attaché type carrying case. Optional extras include rechargeable batteries, and various rods, swivel and straight clamps, to enable use in open and conduit type flows. Available also are the soft type field carrying case and a battery charger.

Aqua Data Ltd also provides, and can supply, non-standard instrumentation and accessories for various specific flow/velocity monitoring tasks, in accordance with the customer's specification.

Requests for dealer information and any other enquiries are very welcome.

 This instrument is designed to meet the requirements of the EC directive on Electromagnetic Compatibility, subject to the following conditions:

- The instrument uses special measurement techniques to reject normal external electromagnetic fields. Readings may become erratic if used in the presence of very strong electric or magnetic fields (e.g. beneath high voltage power transmission lines).
- The velocity probe is an extremely sensitive device intended for use in water or other conductive fluids. Electrostatic discharge to the electrodes may cause damage, and the probe should not be polished with a dry cloth.

Address all correspondence and enquiries to:

Aqua Data Ltd

The John Galt Building
Old Witney Road
Eynsham
Oxfordshire
OX29 4PU
United Kingdom

Telephone: +44 (0)1865 236030
Email: sales@aqua-data.com

Specifications

Measurement range	0 mm s ⁻¹ to 4000 mm s ⁻¹
Accuracy	±0.5 % (typ) ±5 mm s ⁻¹
Cable length	3 m (standard)
Batteries	10 × MN1400, LR14, C-size, or similar
RS-232	Baud: 9600 Start bits: 1 Parity: None Stop bits: 1 Data bits: 8
Operating temperature range: surface unit	-5 °C to 50 °C
Operating temperature range: velocity probe	-5 °C to 70 °C
Storage temperature	-20 °C to 50 °C
Environmental sealing	IP67

Operation

Introduction

The Sensa RC2 series of meters exploit the Faraday effect of electromagnetic induction whereby a magnetic field induces an electric potential in a moving conductor.

An alternating current is passed through a coil in the velocity probe, which sets up an alternating field in the probe head and surrounding water. Movement of the water past the probe causes an electric potential in the water, which is detected by two stainless steel electrodes in the probe. This is then amplified and transmitted through the connecting cable to the surface unit, where the velocity signal is detected and digitised.

Features

The meter uses an electromagnetic sensor head housed in a streamlined epoxy resin moulding. It has no moving parts and requires no maintenance other than occasional cleaning. The control electronics and display are housed in a water-resistant box suitable for use in humid environments and inclement weather. While not guaranteed to be immersion proof it is anticipated that the unit will survive temporary immersion in-line with IP67 standards.

The RC2dl surface unit features non-volatile storage, a real-time clock and an RS232 output to facilitate data logging. The unit is multilingual and has user-selectable units for the flow display.

To preserve battery life, the unit will shut down automatically if no buttons are pressed for thirty minutes.

Connection

Probe

Ensure the surface unit is switched off. The Sensa RC2dl velocity probe is connected to the surface unit via the socket of the left hand side of the unit. The connector is non-reversible and care should be taken to align it correctly.

RS232

Wiring of the RS232 output lead to an external device should only be undertaken by a competent person and with proper reference to both devices' instructions.

The RS232 interface is available via the environmental connector on the right hand side of the surface unit. The connections are as follows:

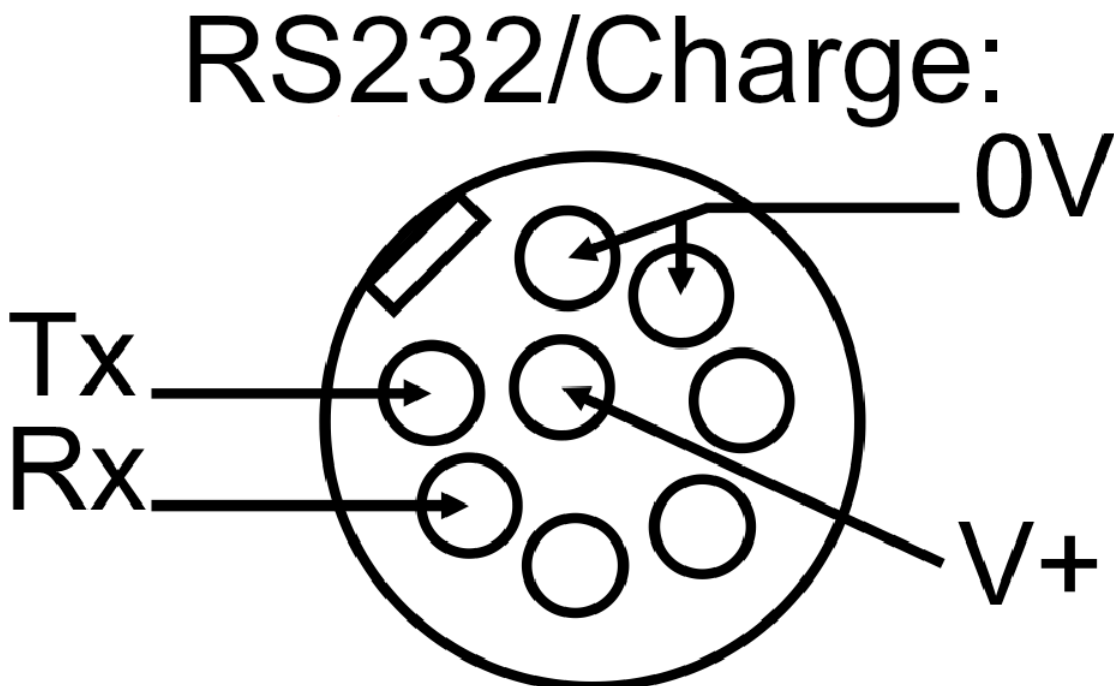

The unit will output the log data in a CSV format, ready for import into a spreadsheet application.

Charging

Rechargeable batteries are optional in the Sensa RC2dl unit, and all of the circuitry required to facilitate use and charging of rechargeable batteries is fitted as standard.

The rechargeable batteries recommended are of the Nickel-Metal-Hydride type, and require no maintenance other than correct charging.

To maximise the life of the Ni-MH cells, it is recommended that they are completely discharged before being fully recharged. Operating time should be in excess of 10 hours of continuous use. Depending on the type of application some users may find that a weekly charge is sufficient. However, an overnight charge will never do any harm.

The charging interface is available via the environmental connector on the right hand side of the surface unit. The connections to the plug should be made as follows:

AQUADATA

Voltage	Pin number	Wire Colour
13-16	8	RED
0	6	BLACK

A smart charger, capable of detecting battery type and charge state *must* be used. It is highly recommended that a charger be supplied by the manufacturer (or dealer), as the use of non-approved charger units may invalidate the given warranty conditions.

Changing Batteries

When not using rechargeable batteries, it is recommended that leak-proof alkaline 'long-life' type cells are used.

Never attempt to recharge alkaline or other primary cells.

Accesses to the battery compartment is via the hinged top lid. This may be opened by undoing the four cross-head screws, located one in each corner of the lid. These screws should be treated with care and lid put back *firmly* (but not screwed-on excessively) to attain IP67 sealing.

Take extra care to note correct polarity of batteries in their holders.

Although all care has been taken to minimise the chances of water entering the display unit during battery changing, it should be noted that battery changing should be done in the cleanest, driest available place, and definitely not under direct rain conditions.

Ensure the batteries are in good contact with the terminals of the holders: corrosion or contaminants such as oil may lead to a poor battery connection.

Cleaning

It is recommended that the probe be cleaned daily with mild detergent solution and a soft cloth. The surface unit may be wiped with a damp cloth.

Usage

Surface unit:

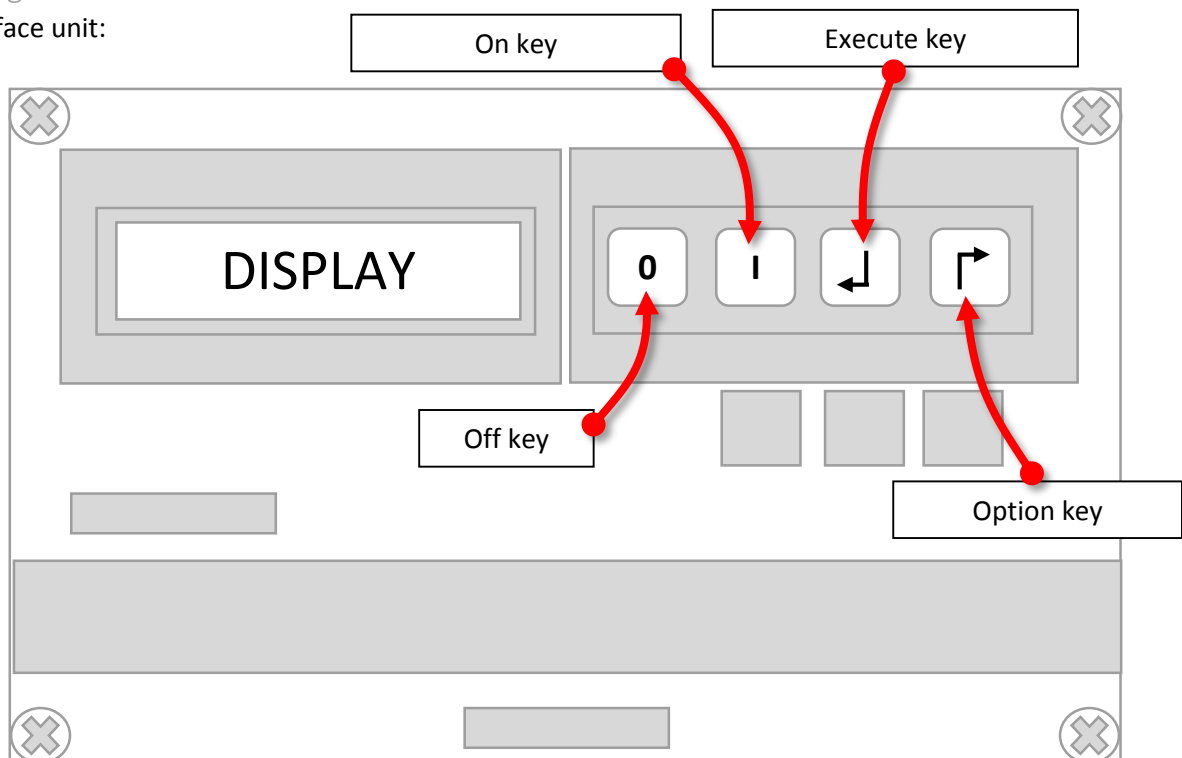

The off key switches off the unit and terminates any sequence.

The on key switches on the unit if the unit is off, and toggles the backlight if the unit is on.

The execute key is used for entering sub menus, advancing through the log display, editing settings, and capturing data points.

The option key is for advancing through menus or advancing through edit sequences.

Power-up

On power-up, the RC2dl will display some system information including the serial number and the unit version. If the battery is low, a warning will also display after the unit version.

Default screen

The default screen shows the flow measurement in the user-selected units in real-time; user can also set screen to update after pre-defined periods (see average option in options menu). Pressing the execute button will create a new entry in the log with the current date, time, and flow rate measurement. Pressing the option key will advance to the next menu. Pressing the on key will toggle the backlight.

View log menu

The *view log* menu enables the user to view the log. Press the option key to advance to the next menu, or press the execute key to view the log. The unit displays the log entries in reverse-chronological order, and displays each entry's information – the date, the time, and the flow – in sequence. Press the execute key to advance through the entries in the log or press the option key to exit.

Download log menu

The *download log* menu enables the user to transmit the data in the log to a host computer using the RS232 interface (data will be in mm per second regardless of user unit setting). Press the option key to advance to the options menu, or follow the following steps to transmit the data.

1. Connect the RC2dl to the computer, and open a terminal emulator.
2. Configure the terminal software for 9600 baud, 8N1, without flow control. If the terminal software is able to log to a file, enable that now and specify a .csv file to easily import the information into a spreadsheet application.
3. Press the execute key to transmit the data.

Options menu

The *options* menu allows the user to edit the system settings. Press the option key to return to the default screen, or press the execute key to enter the options sub-menu.

In the options sub-menu, press the option key to cycle through the settings, or execute to change the setting. Pressing execute when exit is displayed on screen will return the user to the default screen.

- To edit the time, press execute when the time is displayed on screen. The hours value will blink, and can be incremented by pressing the execute key. Once the value is correct, press the option key to advance to the minutes setting. The minutes will blink, and can be incremented by pressing the execute key. Once the value is correct, press the option key again to confirm the time. The seconds will be set to zero automatically.
- The date is edited using a similar strategy, use execute to increment the current value, and option to advance to the next value.
- The average option, when enabled, shows an average reading every 2, 5, 10, 15, 20, 30, 50 or 60 seconds. When active, the display will alternate every two seconds between the average reading and a countdown of the time remaining before the next reading. Enable this when the flow rate is changing too rapidly to be easily seen. Press the execute key with the average setting on the screen to cycle through the different averaging periods.

- The sounder option enables auditory feedback for key presses. Press the execute key with the sounder setting on the screen to toggle between sounder on and sounder off.
- The system language can be changed by pressing the execute key when the current language setting is on screen.
- The flow display units can be changed by pressing the execute key when the current unit setting is on screen.

Sensa RC2dl hints and tips for best operation

Sensa RC2dl is an extremely sensitive, but also robust instrument requiring minimum maintenance, and very few simple precautions to ensure for its best performance at all times.

In this respect, the following simple precautionary measures should be observed:

- During manufacture various chemicals and release agents are applied to the velocity probe head, traces of which can still be left on the head prior to shipment. These and other impurities may affect the sensitivity and performance of the instrument, especially at the low end of the velocity scale. It is therefore good practice to clean the probe's electrodes (i.e. the two dotted metal points) with a mild domestic type solution before use. The aim is to achieve good *wetting* of the electrodes' surface. This can be observed by noticing that water applied to the probe's surface does not run off immediately or forms into globules. Likewise, any greasy material collected over the electrodes is also likely to impair the instrument's performance, especially if it is used and cleaned infrequently. In the absence of domestic detergent, *rubbing-off* the electrodes with clean (non-greasy) sand or soil which is rinsed off afterwards, would also help and be sufficient.
- When using the system in very low conductivity solutions, particularly at very low velocities as may be found under various laboratory and likewise applications, it is recommended that a small amount of salt be added to the liquid if required. About 1 gram per 5 litres of liquid would be sufficient.
- It is further recommended that the velocity probe when used, is connected to the stainless steel rod whenever possible. This is because good grounding of the probe (i.e. its rear end stainless steel neck) is vital for proper performance of the instrument.
- Finally, to check if the instrument may be faulty, the first and simplest test is to check its readings in absolutely still water which is fully and properly grounded. However, it should be remembered that absolutely still water is very difficult to achieve. Small convection, etc, currents are bound to be readily detected and sensed by this instrument.